

THIS DRAWING IS UNPUBLISHED. RELEASED FOR PUBLICATION
 © COPYRIGHT - By - ALL RIGHTS RESERVED.

LOC	DIST	REVISIONS			
P	LTR	DESCRIPTION	DATE	DWN	APVD
FT	47	AM1	REVISED PER ECO-15-003583	07MAR2015	NK MZ

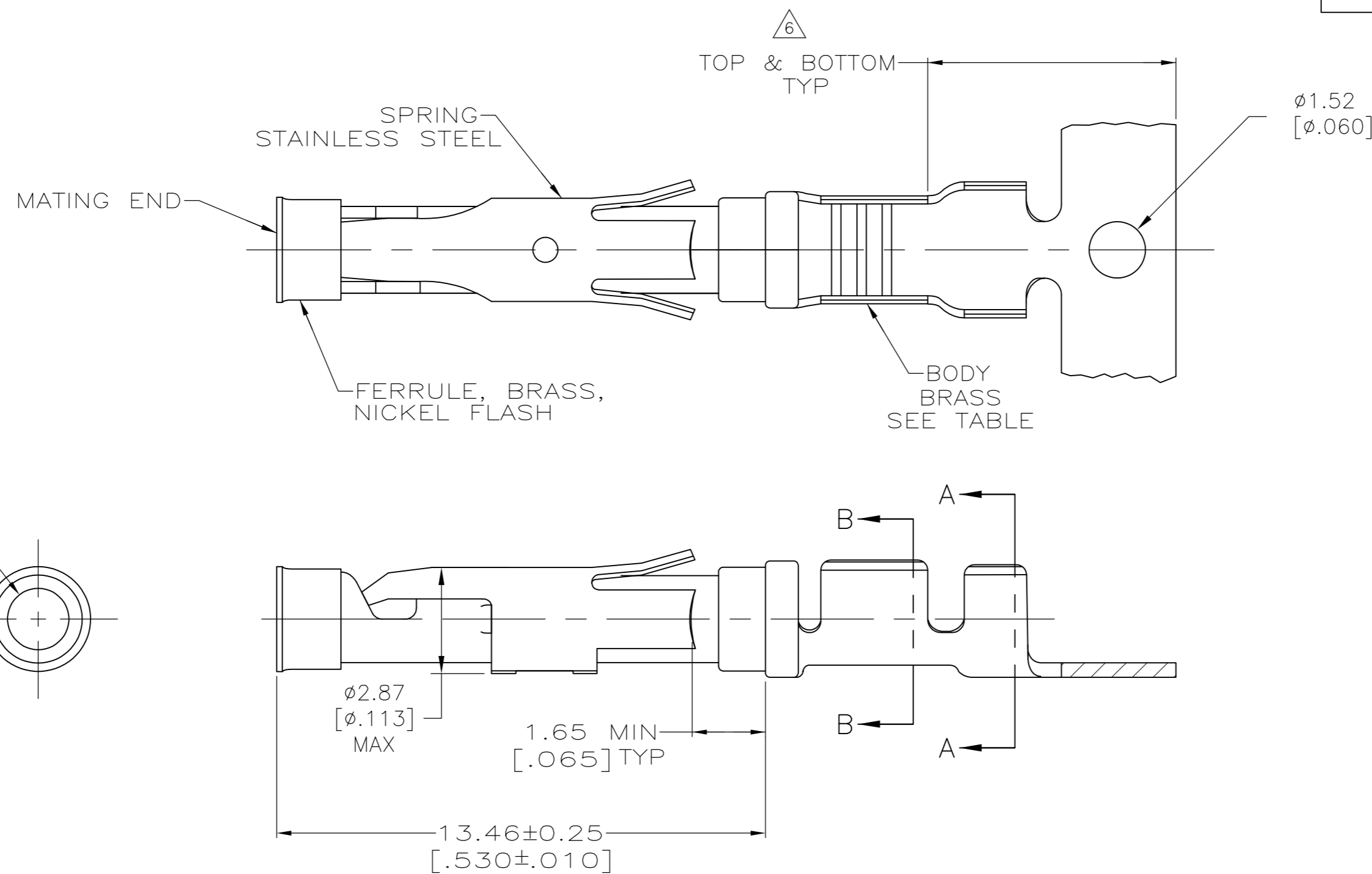

1.27µm [.000050] MIN TIN PER MIL-T-10727 OVER
 0.76µm [.000030] MIN NICKEL PER QQ-N-290.

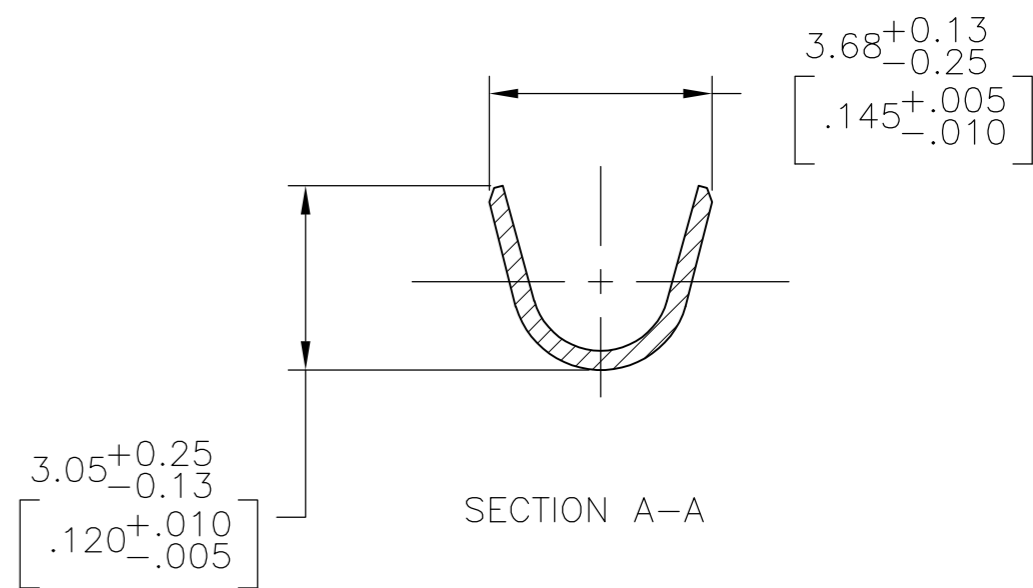
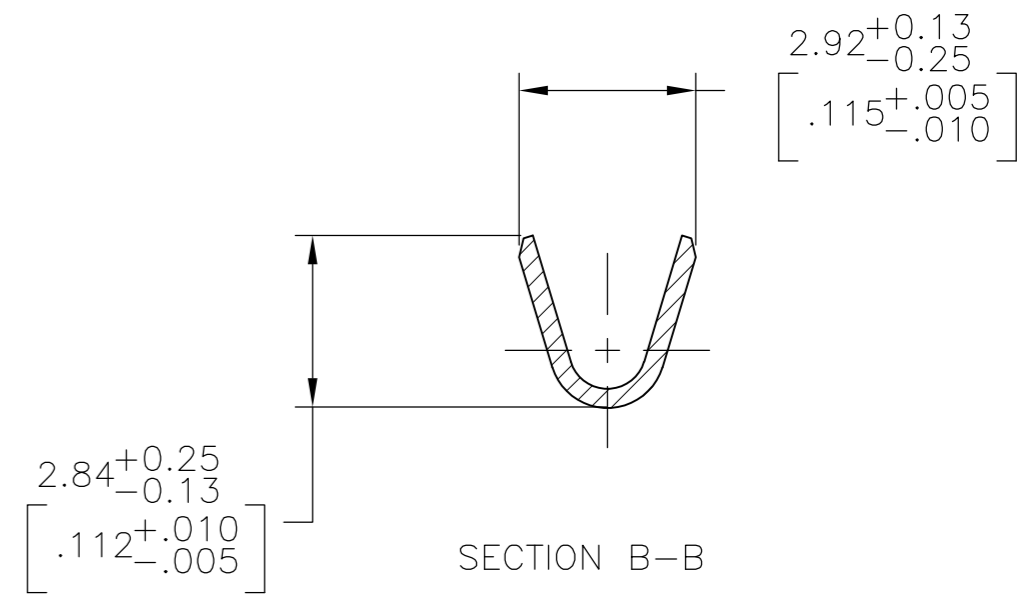
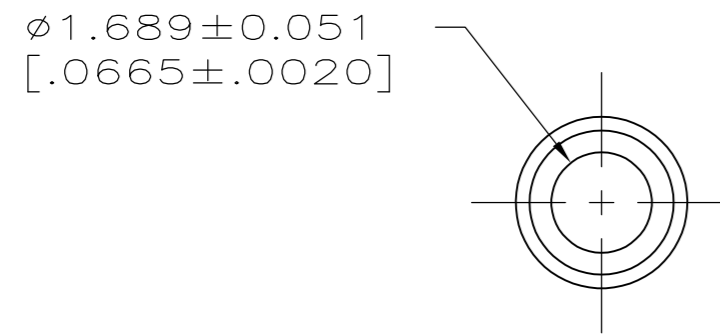

- 1 0.76µm [.000030] MIN GOLD PER MIL-G-45204 ON MATING END FOR A LENGTH OF 5.08 [.200] MIN WITH 1.27µm [.000050] MIN MATTE TIN PLATE IN WIRE CRIMP AREA, BOTH OVER 0.76µm [.000030] MIN NICKEL PER QQ-N-290.
- 2 1.27µm [.000050] MIN TIN-LEAD PER MIL-T-10727 OVER 0.76µm [.000030] MIN NICKEL PER QQ-N-290.
- 3 0.76µm [.000030] MIN GOLD PER MIL-G-45204 ON MATING END FOR A LENGTH OF 5.08 [.200] MIN WITH A UNIFORM GRADIENT TO 0.25µm [.000010] MIN GOLD PER MIL-G-45204 ON THE REMAINDER OVER 0.76µm [.000030] MIN NICKEL PER QQ-N-290.
- 4 0.38µm [.000015] MIN GOLD PER MIL-G-45204 ON MATING END FOR A LENGTH OF 5.08 [.200] MIN WITH 1.27µm [.000050] MIN MATTE TIN PLATE IN WIRE CRIMP AREA, BOTH OVER 0.76µm [.000030] MIN NICKEL PER QQ-N-290.
- 5 1.27µm [.000050] MIN GOLD PER MIL-G-45204 ON MATING END FOR A LENGTH OF 5.08 [.200] MIN WITH GOLD FLASH ON REMAINDER OVER 1.90µm [.000075] MIN NICKEL PER QQ-N-290.
- 6 GOLD PLATING NEED NOT APPEAR IN THIS AREA EXCEPT 1-66100-3 HAS GOLD PLATING ON INSULATION BARREL.
- 7 REVERSE REELED FOR MINI-APPLICATOR.
- 8 ALL PART NUMBERS ON THIS DRAWING HAVE APPLICATION TOOLING AVAILABLE TO CRIMP 18-16 WIRE AWG WITH AN INSULATION RANGE OF Ø2.03-2.54 [.080-.100]. ADDITIONALLY, LOOSE PIECE AND REVERSE REELED PART NUMBERS HAVE APPLICATION TOOLING AVAILABLE TO CRIMP 0.75mm² WIRE WITH AN INSULATION RANGE OF Ø1.35-1.65 [.053-.065] OR 1.0mm² WIRE WITH AN INSULATION RANGE OF Ø1.45-1.80 [.057-.071].
- 9 0.38µm [.000015] MIN GOLD PER MIL-G-45204 ON MATING END FOR A LENGTH OF 5.08 [.200] MIN, 1.27µm [.000050] MIN TIN-LEAD PER MIL-T-10727 FOR A LENGTH OF 5.69 [.224] MIN ON OPPOSITE END, BOTH OVER 1.27µm [.000050] MIN NICKEL PER QQ-N-290 ON ENTIRE CONTACT.

SUPERCEDED BY 66100-8
 OBSOLETE

TE ASSEMBLY LOCATION	REELING	BODY FINISH	LOOSE PIECE REF	PART NO.
EUROPE	7	10	NONE	2-66100-2
	7	1	NONE	2-66100-1
	STANDARD	10	1-66101-9	2-66100-0
	7	10	1-66101-9	1-66100-9
	7	9	1-66101-4	1-66100-7
	-	5	-	1-66100-3
	7	1	66101-4	66100-9
	7	4	66101-3	66100-8
	7	2	66101-2	66100-7
	7	3	66101-1	66100-6
NORTH AMERICA	STANDARD	1	66101-4	66100-4
	STANDARD	4	66101-3	66100-3
	STANDARD	2	66101-2	66100-2
	STANDARD	3	66101-1	66100-1
	STANDARD	1	66101-4	66100-4
	STANDARD	4	66101-3	66100-3

THIS DRAWING IS A CONTROLLED DOCUMENT.

DIMENSIONS: mm [INCHES]	TOLERANCES UNLESS OTHERWISE SPECIFIED:	DWN V. FURLER 11JUL03	
	0 PLC ± -	CHK G. STEINHAEUER 11JUL03	
	1 PLC ± -	APVD G. STEINHAEUER 11JUL03	
	2 PLC ± 0.13 [.005]	PRODUCT SPEC	
	3 PLC ± -	APPLICATION SPEC	
MATERIAL SEE CALLOUTS	FINISH SEE CALLOUTS	WEIGHT -	NAME: SOCKET ASSEMBLY, .062, TYPE III+ SIZE: A2 CAGE CODE: 00779 DRAWING NO: C-66100 RESTRICTED TO: - SCALE: 8:1 SHEET: 1 OF 1 REV: AM1